

(1) ILLUST		(2) SOURCE, MAINT AND RECOVERABILITY CODE				(3) FEDERAL STOCK NO	(4) DESCRIPTION	(5) UNIT OF ISSUE	(6) QTY INC IN UNIT	(7) 15-DAY MAINT ALW PER 100 EQUIP	
(a) FIG NO	(b) ITEM NO	(a) MATERIEL CODE	(b) SOURCE	(c) MAINTENANCE LEVEL	(d) RECOVERABILITY				(a) CO OR BTRY	(b) CO SEP BN OR RECT	
							13 - WHEELS - Continued				
							<u>1311 - REAR HUB, DRUM ASSEMBLY AND RELATED PARTS (Fig. 55)</u>				
55	1	P	O			2530-737-4988	SEAL: oil, type mw, 1-3/8 x 2, 286 x 1/4 (7374988) -----	ea	2		
55	2	P	O			3110-100-3546	CONE TAPERED ROLLER BEARING: mil-std-code 771 25877-3000 (includes rollers and cage, sr, 1.3750 bore, 0.9688 w shaft) (705447)	ea	2		
55	3	P	O			3110-100-0551	CUP, TAPERED ROLLER BEARING: mil-std-code 711- 25821-1000 sr, si, no. 2 tol, 1/32 corner rad, 2.8750 od, 0.7500 lg (706857)	ea	2		
55	4	P	O			2520-737-4981	SHIM SET: bearing (7374981) ----- Composed of: 4 SHIM 0.003 (78080-20010X) 4 SHIM 0.005 (78080-17521-2) 2 SHIM 0.010 (78080-17521-3) 2 SHIM 0.030 (78080-17521-4)	ea	≠		
55	5	C	O			2520-735-1313	RETAINER: bearing (7351313) -----	ea	2		
55	7	C	O			2530-318-4335	SEAL: oil, rear axle shaft, outer, assy (8332519)-----	ea	4		
55	8	C	O	R		2530-301-7763	HUB: rear (8333106) -----	ea	2		
55	9	C	O			5315-282-0360	KEY, MACHINE: rear axle shaft (7375136)-----	ea	2		
55	10	C	O			5310-703-2606	NUT: shaft (7032606) -----	ea	2		
55	11	P	O			5315-059-0378	PIN, COTTER: S, cd- or zn-pltd, 1/8 x 1-1/2 rear axle shaft nut (590378)				
55	12	C	O			2520-737-5143	CAP: hub (7375143)-----	ea	2		
55	13	P	O			5306-732-8294	BOLT RIBBED SHOULDER: rivet type, S, carburized case harden, 1/2-20NF-3 rolled thd lh thd hub (7328294)	ea	5		
55	13	P	O			5306-732-8293	BOLT RIBBED SHOULDER: rivet type, S, carburized case harden 1/2-20NF-3 rolled thd rh thd hub (7328293)	ea	5		

(1) ILLUST		(2) SOURCE, MAINT AND RECOVERABILITY CODE				(3) FEDERAL STOCK NO	(4) DESCRIPTION	(5) UNIT OF ISSUE	(6) QTY INC IN UNIT	(7) 15-DAY MAINT ALW PER 100 EQUIP	
(a) FIG NO	(b) ITEM NO	(a) MATERIEL CODE	(b) SOURCE	(c) MAINTENANCE LEVEL	(d) RECOVERABILITY					(a) CO OR BTRY	(b) CO SEP BN OR REGT
13 - WHEELS - Continued 1311 - REAR HUB DRUM ASSEMBLY AND RELATED PARTS PARTS (Fig. 55)											
54	11	P	O			5305-013-3757	SCREW, MACHINE: fl-hd, S, cd- or zn-pltd, 1/4-20UNC-2A x 3/8 (133757)	ea	6		
54	12	P	O			5310-264-1929	NUT, CONE SEAT HEXAGON: S, cyanide case hardened, parkerized, 1/2NF-21ht wheel mounting hub (5232404)	ea	5		
54	12	P	O			5310-523-2405	NUT, CONE SEAT HEXAGON: S, cyanide case hardened, 1/2-20NF-2 rhg wheel mounting hub (5232405)	ea	5		

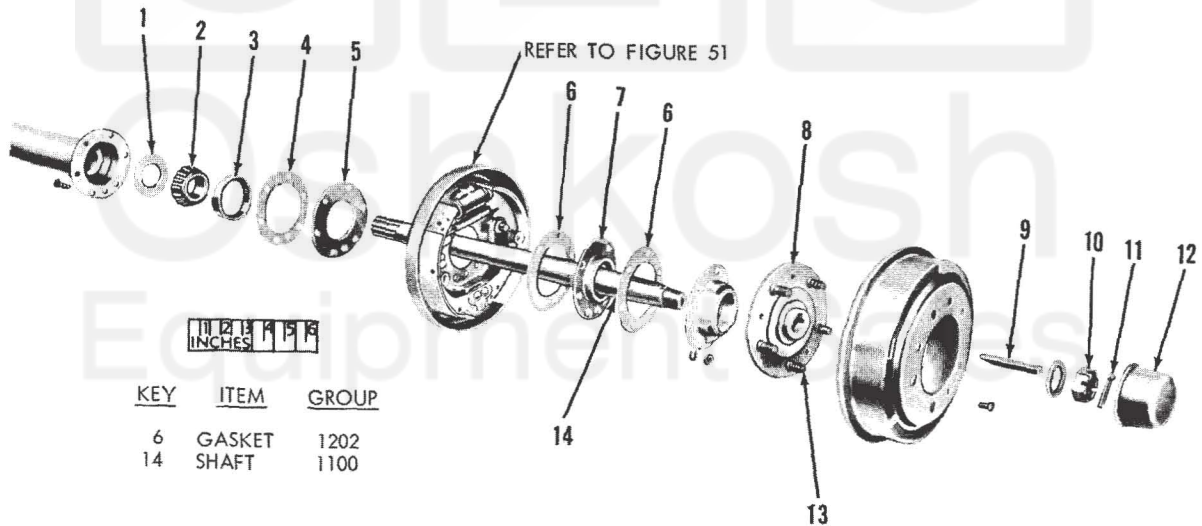

ORD E64899

Figure 55. Rear hub, drum assembly and related parts - exploded view